

Large Flange / Splined / Metric

Optimal for high punch-out application. Dimensioned for installation into hard metric holes. Tapered entry. Splined body improves torque-to-turn resistance.

Material: 304 Stainless Steel

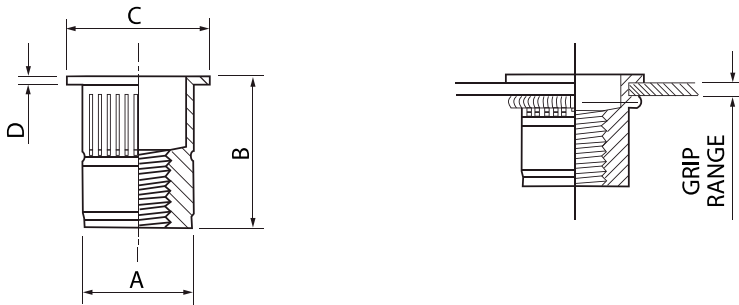

Thread Size	SKU	Grip Range mm	Hole Size mm	A mm	B mm	C mm	D mm	Pull-Out KN	Push-Out KN	Torque-To-Turn* Nm
M3	43LFS3SP	0.3-2.0	5.0	4.95	9.8	8.0	0.8	5.3	3.3	3.4
	43LFS4SP	0.3-2.5	6.0	5.95	12.0	9.0	1.0	9.8	4.9	4.9
M4	43LFS4SP2	2.5-4.0	6.0	5.95	13.5	9.0	1.0	9.8	4.9	4.9
	43LFS5SP	0.3-3.0	7.0	6.95	13.0	10.0	1.0	15.7	6.9	8.8
M5	43LFS5SP2	3.0-4.5	7.0	6.95	14.5	10.0	1.0	15.7	6.9	8.8
	43LFS6SP	0.5-3.0	9.0	8.95	15.5	12.0	1.5	20.6	9.8	15.7
M6	43LFS6SP2	3.0-5.0	9.0	8.95	17.5	12.0	1.5	20.6	9.8	15.7
	43LFS8SP	0.5-3.0	11.0	10.95	17.5	15.0	1.5	29.4	12.7	29.4
M8	43LFS8SP2	3.0-5.5	11.0	10.95	20.0	15.0	1.5	29.4	12.7	29.4
	43LFS10SP	1.0-3.5	13.0	12.95	21.0	17.0	2.0	42.2	15.7	39.2
M10	43LFS10SP2	3.5-6.0	13.0	12.95	23.5	17.0	2.0	42.2	15.7	39.2

Torque-To-Turn *

Minimum torque applied to cause the fastener to turn in the parent material.

Dimensions and specifications are subject to change without notice.

The test data provides approximate strength values averaged in multiple tests in various materials and thicknesses.

We recommend testing your application when an exact strength figure is required or the load to be applied comes close to the published data.

