

AL Series / Large Flange Low Profile/ Splined / UNC

Highest resistance to vibration and spin-out of all round bodied inserts. Flange with near flush finish. Very wide grip range. Low torque required to install.

Material: Steel to AISI 1010/1008

Finish: Zinc Clear Cr3

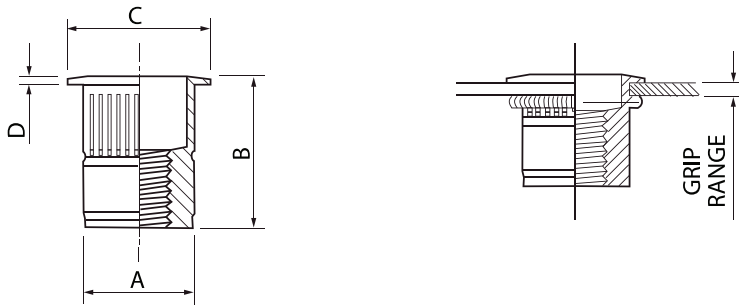

Thread Size	SKU	Grip Range mm	Hole Size mm	A mm	B mm	C mm	D mm	Pull-Out KN	Push-Out KN	Torque-To-Turn* Nm
3/16" (10-24)	43ALC1024SP	0.5-3.3	7.6	7.52	12.83	10.54	0.76	—	—	—
1/4"	43ALC14SP	0.7-4.2	10.0	9.91	15.49	12.70	0.76	12.7	4.9	19.6
5/16"	43ALC516SP	0.7-3.8	13.5	13.46	18.42	17.40	0.89	22.6	6.9	24.5
3/8"	43ALC38SP	0.7-3.8	13.5	13.46	18.42	17.40	0.89	22.6	6.9	53.9

Torque-To-Turn *

Minimum torque applied to cause the fastener to turn in the parent material.

Dimensions and specifications are subject to change without notice.

The test data provides approximate strength values averaged in multiple tests in various materials and thicknesses.

We recommend testing your application when an exact strength figure is required or the load to be applied comes close to the published data.

