

Disclaimer: Images are for illustrative purposes.

Cage Nut

Thread Type: Metric - Coarse

Thread Direction: Right Hand

Material: Stainless Steel

Class Grade: A2-70 G304

Corrosion Protection Level: Excellent

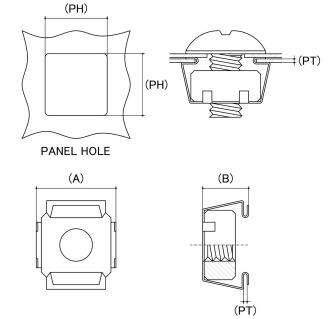

Size	Thread Pitch (mm)	Thread Type	Overall Nut Height (B) (mm)	Nut Length (L) (mm)	Nut Width (A) (mm)	Panel Thickness (PT) (mm)		Panel Hole Size (PH) (mm)	sku (Part Number)
			Nom	Nom	Nom	Min	Max	Nom	
M5	0.80mm	Coarse	8.80	13.00	13.20	0.70	1.60	9.50	41CNS5
M5	0.80mm	Coarse	9.70	13.00	13.20	1.70	2.70	9.50	41CNS52
M6	1.00mm	Coarse	8.50	13.00	13.20	0.70	1.60	9.50	41CNS6
M6	1.00mm	Coarse	9.30	13.00	13.20	1.60	2.65	9.50	41CNS62
M6	1.00mm	Coarse	10.20	13.00	13.20	2.65	3.25	9.50	41CNS63
M8	1.25mm	Coarse	11.30	16.20	16.40	0.70	1.60	12.80	41CNS8
M8	1.25mm	Coarse	10.50	16.20	16.40	1.80	2.65	12.80	41CNS82
M8	1.25mm	Coarse	11.20	16.20	16.40	2.65	3.25	12.80	41CNS83
M10	1.50mm	Coarse	11.70	16.20	16.40	2.65	3.25	12.80	41CNS10

Disclaimer:

Dimensional data and technical information was obtained from publically available sources and not acquired through standard agencies. It has been completed and compiled for reference purposes only; where discrepancies are found they are subject to change without notice. Bolt & Nut Australia makes no warranties or representations regarding the accuracy and validity of the compiled information and data. Contact the relevant standard authorities for accurate and detailed information.

© Bolt & Nut Australia Pty Ltd. All rights reserved.

Version: 17 Mar 2026