

Disclaimer: Images are for illustrative purposes.

Cage Nut

Thread Type: UNC / BSW - Coarse

Thread Direction: Right Hand

Material: Carbon Steel

Class Grade: Low Tensile Class 4.6

Finish: Zinc Yellow

Corrosion Protection Level: Moderate

Comments: UNC and BSW have the same thread per inch (TPI) value, except for 1/2"

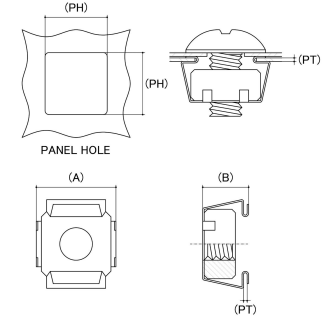

Size	Thread Pitch (TPI)	Thread Type	Overall Nut Height (B) (mm)	Nut Length (L) (mm)	Nut Width (A) (mm)	Panel Thickness (PT) (mm)		Panel Hole Size (PH) (mm)	sku (Part Number)
			Nom	Nom	Nom	Min	Max	Nom	
3/16" (#10-24)	24 TPI	Coarse	8.85	13.00	13.20	0.70	1.60	9.50	41CNC316
3/16" (#10-24)	24 TPI	Coarse	9.90	13.00	13.20	1.80	2.65	9.50	41CNC3162
1/4"	20 TPI	Coarse	9.05	13.00	13.20	0.70	1.60	9.50	41CNC14
1/4"	20 TPI	Coarse	9.30	13.00	13.20	1.80	2.65	9.50	41CNC142
5/16"	18 TPI	Coarse	10.20	16.20	16.40	0.70	1.60	12.80	41CNC516
5/16"	18 TPI	Coarse	12.05	16.20	16.40	1.60	2.65	12.80	41CNC5162

Disclaimer:

Dimensional data and technical information was obtained from publically available sources and not acquired through standard agencies. It has been completed and compiled for reference purposes only; where discrepancies are found they are subject to change without notice. Bolt & Nut Australia makes no warranties or representations regarding the accuracy and validity of the compiled information and data. Contact the relevant standard authorities for accurate and detailed information.

© Bolt & Nut Australia Pty Ltd. All rights reserved.

Version: 17 Mar 2026