

Disclaimer: Images are for illustrative purposes.

Flange Nut

Thread Type: Metric - Coarse

Thread Direction: Right Hand

Material: Stainless Steel

Class Grade: A2-70 G304

Corrosion Protection Level: Excellent

Standard: DIN 6923

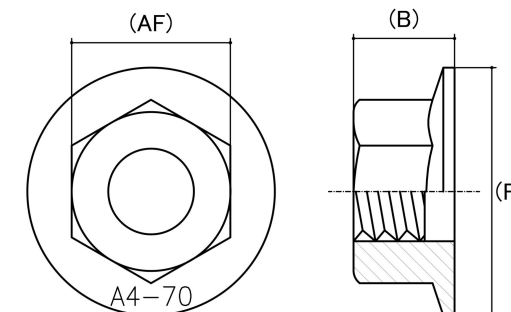

Size	Thread Pitch (mm)	Thread Type	Overall Nut Height (B) (mm)		Hex Height (H) (mm)		Flange Diameter (F) (mm)		Across Flats (AF) (mm)		Spanner Size (AF) (mm)	sku (Part Number)
			Min	Max	Min	Max	Min	Max	Min	Max		
M4	0.70mm	Coarse	4.35	4.65	4.35	4.65	9.78	10.00	6.78	7.00	7mm	41FLS4N
M5	0.80mm	Coarse	4.70	5.00	4.70	5.00	11.50	11.80	7.78	8.00	8mm	41FLS5N
M6	1.00mm	Coarse	5.64	6.00	5.70	6.00	13.90	14.20	9.78	10.00	10mm	41FLS6N
M8	1.25mm	Coarse	7.60	8.00	7.60	8.00	17.60	17.90	12.73	13.00	13mm	41FLS8N
M10	1.50mm	Coarse	9.60	10.00	9.60	10.00	21.50	21.80	14.73	15.00	15mm	41FLS10N
M12	1.75mm	Coarse	11.60	12.00	11.60	12.00	25.70	26.00	17.73	18.00	18mm	41FLS12N

Disclaimer:

Dimensional data and technical information was obtained from publically available sources and not acquired through standard agencies. It has been completed and compiled for reference purposes only; where discrepancies are found they are subject to change without notice. Bolt & Nut Australia makes no warranties or representations regarding the accuracy and validity of the compiled information and data. Contact the relevant standard authorities for accurate and detailed information.

© Bolt & Nut Australia Pty Ltd. All rights reserved.

Version: 17 Mar 2026