

Disclaimer: Images are for illustrative purposes.

Flange Nyloc Insert Nut

Thread Type: Metric - Coarse

Thread Direction: Right Hand

Material: Carbon Steel

Class Grade: High Tensile Class 10

Finish: Zinc Yellow

Corrosion Protection Level: Moderate

Standard: DIN 6926

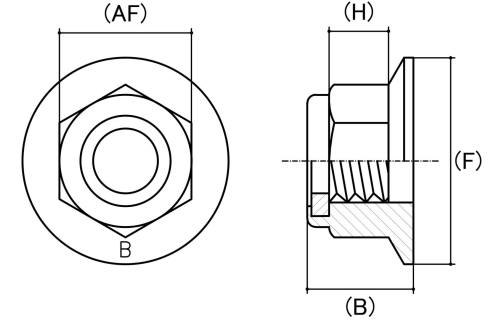

Size	Thread Pitch (mm)	Thread Type	Overall Nut Height (B) (mm)		Hex Height (H) (mm)	Flange Diameter (F) (mm)	Across Flats (AF) (mm)		Spanner Size (AF) (mm)	sku (Part Number)
			Min	Max	Nom	Nom	Min	Max		
M12	1.75mm	Coarse	15.67	16.00	8.55	25.00	17.73	18.00	18mm	41FLN12ZY
M14	2.00mm	Coarse	17.68	18.20	9.35	29.00	20.67	21.00	21mm	41FLN14ZY
M16	2.00mm	Coarse	19.46	20.00	11.30	34.00	23.67	24.00	24mm	41FLN16ZY
M20	2.50mm	Coarse	24.00	24.80	12.60	42.00	29.16	30.00	30mm	41FLN20ZY
M24	3.00mm	Coarse	29.00	29.80	15.60	45.00	35.16	36.00	36mm	41FLN24ZY

Disclaimer:

Dimensional data and technical information was obtained from publically available sources and not acquired through standard agencies. It has been completed and compiled for reference purposes only; where discrepancies are found they are subject to change without notice. Bolt & Nut Australia makes no warranties or representations regarding the accuracy and validity of the compiled information and data. Contact the relevant standard authorities for accurate and detailed information.

© Bolt & Nut Australia Pty Ltd. All rights reserved.

Version: 17 Mar 2026