

*Disclaimer: Images are for illustrative purposes.*

## Flange Nyloc Insert Nut

**Thread Type:** UNF - Fine

**Thread Direction:** Right Hand

**Material:** Carbon Steel

**Class Grade:** High Tensile Grade 5

**Finish:** Zinc Plated

**Corrosion Protection Level:** Moderate

**Standard:** DIN 6926

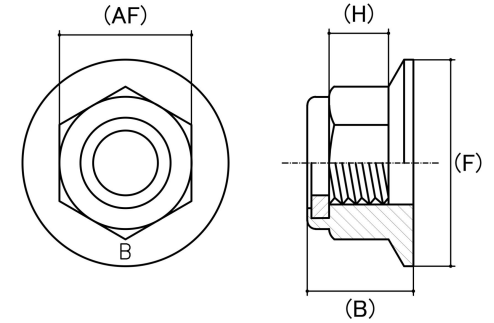

Size	Thread Pitch (TPI)	Thread Type	Overall Nut Height (B) (mm)		Hex Height (H) (mm)	Flange Diameter (F) (mm)	Flange Thickness (D) (mm)	Across Flats (AF) (mm)		Spanner Size (AF) (inches)	sku (Part Number)
			Min	Max	Nom	Nom	Nom	Min	Max		
1/4"	28 TPI	Fine	6.90	7.15	3.59	14.00	1.66	10.88	11.16	7/16"	41FLNF14
3/8"	24 TPI	Fine	10.30	10.60	5.85	20.00	2.65	14.00	14.28	9/16"	41FLNF38
1/2"	20 TPI	Fine	13.60	13.90	6.40	26.80	3.75	18.70	19.05	3/4"	41FLNF12

**Disclaimer:**

Dimensional data and technical information was obtained from publically available sources and not acquired through standard agencies. It has been completed and compiled for reference purposes only; where discrepancies are found they are subject to change without notice. Bolt & Nut Australia makes no warranties or representations regarding the accuracy and validity of the compiled information and data. Contact the relevant standard authorities for accurate and detailed information.

© Bolt & Nut Australia Pty Ltd. All rights reserved.

Version: 17 Mar 2026