

Disclaimer: Images are for illustrative purposes.

Flange Serrated Nut

Thread Type: Metric - Coarse

Thread Direction: Right Hand

Material: Carbon Steel

Class Grade: High Tensile Class 12

Finish: Zinc Flake Silver

Corrosion Protection Level: Excellent

Standard: HEC / CL12

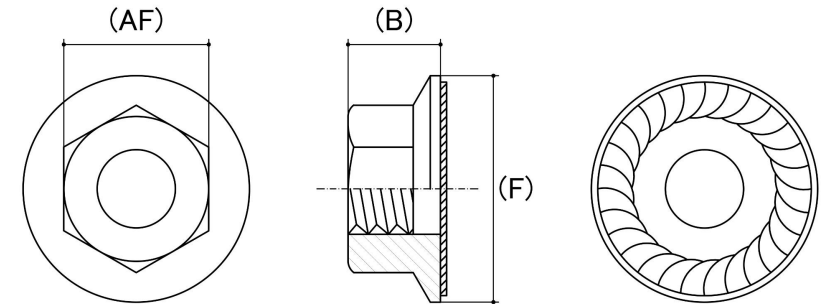

Size	Thread Pitch (mm)	Thread Type	Overall Nut Height (B) (mm)	Flange Diameter (F) (mm)		Across Flats (AF) (mm)		Spanner Size (AF) (mm)	sku (Part Number)
			Nom	Min	Max	Min	Max		
M8	1.25mm	Coarse	7.20	17.90mm	-	12.73	13.00	13mm	41FLD8ZF
M10	1.50mm	Coarse	9.15	21.50	21.80	14.73	15.00	15mm	41FLD10ZF
M12	1.75mm	Coarse	11.00	26.00mm	-	17.73	18.00	19mm	41FLD12ZF
M16	2.00mm	Coarse	16.00	32.00mm	-	23.73	24.00	24mm	41FLD16ZF
M20	2.50mm	Coarse	18.00	39.00mm	-	29.73	30.00	30mm	41FLD20ZF

Disclaimer:

Dimensional data and technical information was obtained from publicly available sources and not acquired through standard agencies. It has been completed and compiled for reference purposes only; where discrepancies are found they are subject to change without notice. Bolt & Nut Australia makes no warranties or representations regarding the accuracy and validity of the compiled information and data. Contact the relevant standard authorities for accurate and detailed information.

© Bolt & Nut Australia Pty Ltd. All rights reserved.

Version: 17 Mar 2026