

*Disclaimer: Images are for illustrative purposes.*

## Flange Serrated Nut

**Thread Type:** UNC / BSW - Coarse

**Thread Direction:** Right Hand

**Material:** Carbon Steel

**Class Grade:** High Tensile Grade 5

**Finish:** Zinc Yellow

**Corrosion Protection Level:** Moderate

**Standard:** IFI 145 / B18 2.2

**Comments:** UNC and BSW have the same thread per inch (TPI) value, except for 1/2"

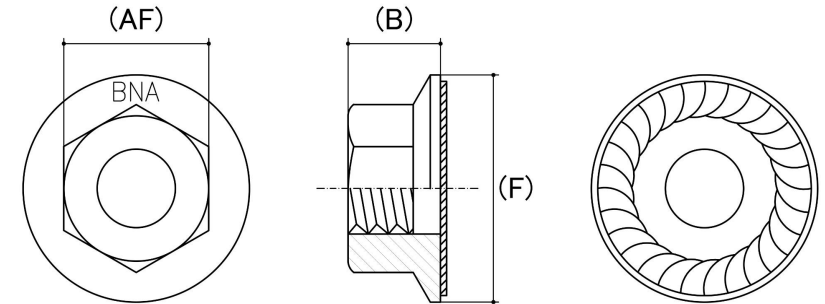

Size	Thread Pitch (TPI)	Thread Type	Overall Nut Height (B) (mm)		Hex Height (H) (mm)	Flange Diameter (F) (mm)		Across Flats (AF) (mm)		Spanner Size (AF) (inches)	sku (Part Number)
			Min	Max	Nom	Min	Max	Min	Max		
1/4"	20 TPI	Coarse	5.64	6.00	3.81	14.58	15.09	10.88	11.16	7/16"	41FLC14ZY
5/16"	18 TPI	Coarse	6.55	7.37	4.32	16.77	17.28	12.43	12.76	1/2"	41FLC516ZY
3/8"	16 TPI	Coarse	8.38	8.81	5.85	18.50	19.05	14.00	14.28	9/16"	41FLC38ZY
7/16"	14 TPI	Coarse	9.50	10.00	5.67	23.10	23.80	17.15	17.48	11/16"	41FLC716ZY
1/2"	13 TPI	Coarse	11.10	11.63	7.88	25.40	26.19	18.70	19.00	3/4"	41FLC12ZY

**Disclaimer:**

Dimensional data and technical information was obtained from publically available sources and not acquired through standard agencies. It has been completed and compiled for reference purposes only; where discrepancies are found they are subject to change without notice. Bolt & Nut Australia makes no warranties or representations regarding the accuracy and validity of the compiled information and data. Contact the relevant standard authorities for accurate and detailed information.

© Bolt & Nut Australia Pty Ltd. All rights reserved.

Version: 17 Mar 2026