

Disclaimer: Images are for illustrative purposes.

Standard Full Nut

Thread Type: BSW - Coarse

Thread Direction: Right Hand

Material: Carbon Steel

Class Grade: Low Tensile Grade 2

Finish: Galvanised

Corrosion Protection Level: Excellent

Standard: AS 2451

Comments: BSW and UNC have the same thread per inch (TPI) value, except for 1/2"

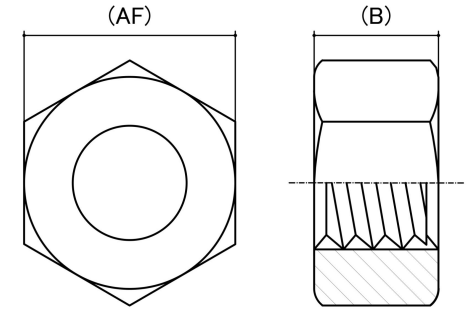

Size	Thread Pitch (TPI)	Thread Type	Overall Nut Height (B) (mm)		Across Flats (AF) (mm)		Spanner Size (AF) (inches)	sku (Part Number)
			Min	Max	Min	Max		
3/16" (#10-24)	24 TPI	Coarse	2.93	3.31	9.20	9.53	23/64"	41W316
1/4"	20 TPI	Coarse	4.57	5.08	9.76	10.00	7/16"	41W14
5/16"	18 TPI	Coarse	5.84	6.35	13.66	13.90	9/16"	41W516
3/8"	16 TPI	Coarse	7.42	7.93	13.66	13.90	9/16"	41W38
1/2"	12 TPI	Coarse	10.59	11.10	20.32	20.83	7/8"	41W12G
1/2"	12 TPI	Coarse	10.59	11.10	20.32	20.83	7/8"	41W12
5/8"	11 TPI	Coarse	13.77	14.27	25.02	25.66	15/16"	41W58G
5/8"	11 TPI	Coarse	13.77	14.27	25.02	25.66	15/16"	41W58
3/4"	10 TPI	Coarse	17.20	17.45	29.85	30.48	1-1/8"	41W34G
3/4"	10 TPI	Coarse	17.20	17.45	29.85	30.48	1-1/8"	41W34
1"	8 TPI	Coarse	21.11	22.53	36.83	37.60	1-1/2"	41W1
1-1/4"	7 TPI	Coarse	28.14	28.58	46.11	47.25	1-7/8"	41W114G

Disclaimer:

Dimensional data and technical information was obtained from publically available sources and not acquired through standard agencies. It has been completed and compiled for reference purposes only; where discrepancies are found they are subject to change without notice. Bolt & Nut Australia makes no warranties or representations regarding the accuracy and validity of the compiled information and data. Contact the relevant standard authorities for accurate and detailed information.