

Disclaimer: Images are for illustrative purposes.

Standard Full Nut

Thread Type: Metric - Coarse

Thread Direction: Right Hand

Material: Carbon Steel

Class Grade: Low Tensile Class 4.6

Finish: Black Zinc

Corrosion Protection Level: Moderate

Standard: AS 1112

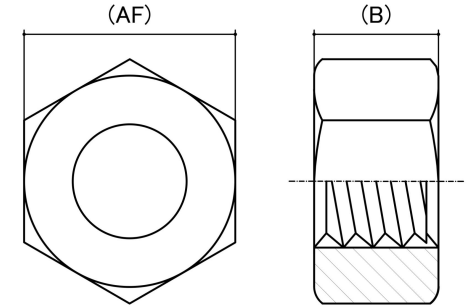

Size	Thread Pitch (mm)	Thread Type	Overall Nut Height (B) (mm)		Across Flats (AF) (mm)		Spanner Size (AF) (mm)	sku (Part Number)
			Min	Max	Min	Max		
M3	0.50mm	Coarse	2.15	2.40	5.32	5.50	5.5mm	413BZ
M4	0.70mm	Coarse	2.90	3.30	6.78	7.00	7mm	414BZ
M5	0.80mm	Coarse	4.40	4.70	7.78	8.00	8mm	415BZ
M6	1.00mm	Coarse	4.90	5.20	9.78	10.00	10mm	416BZ
M8	1.25mm	Coarse	6.44	6.93	12.73	13.00	13mm	418BZ

Disclaimer:

Dimensional data and technical information was obtained from publically available sources and not acquired through standard agencies. It has been completed and compiled for reference purposes only; where discrepancies are found they are subject to change without notice. Bolt & Nut Australia makes no warranties or representations regarding the accuracy and validity of the compiled information and data. Contact the relevant standard authorities for accurate and detailed information.

© Bolt & Nut Australia Pty Ltd. All rights reserved.

Version: 17 Mar 2026