

Disclaimer: Images are for illustrative purposes.

Standard Full Nut

Thread Type: Metric - Coarse

Thread Direction: Right Hand

Material: Nylon

Class Grade: Low Tensile Class 4.6

Finish: White

Corrosion Protection Level: Excellent

Standard: DIN 934

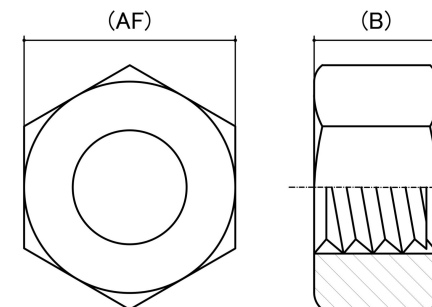

Size	Thread Pitch (mm)	Thread Type	Overall Nut Height (B) (mm)		Across Flats (AF) (mm)		Spanner Size (AF) (mm)	sku (Part Number)
			Min	Max	Min	Max		
M2.5	0.45mm	Coarse	1.75	2.00	4.82	5.00	5mm	41NY25
M3	0.50mm	Coarse	2.15	2.40	5.32	5.50	5.5mm	41NY3
M4	0.70mm	Coarse	2.90	3.30	6.78	7.00	7mm	41NY4
M5	0.80mm	Coarse	3.70	4.00	7.78	8.00	8mm	41NY5
M6	1.00mm	Coarse	4.70	5.00	9.78	10.00	10mm	41NY6
M8	1.25mm	Coarse	6.14	6.40	12.73	13.00	13mm	41NY8
M10	1.50mm	Coarse	7.42	8.00	16.73	17.00	17mm	41NY10
M12	1.75mm	Coarse	9.64	10.00	18.67	19.00	19mm	41NY12
M16	2.00mm	Coarse	12.30	13.00	23.67	24.00	24mm	41NY16
M20	2.50mm	Coarse	15.00	16.00	29.16	30.00	30mm	41NY20

Disclaimer:

Dimensional data and technical information was obtained from publicly available sources and not acquired through standard agencies. It has been completed and compiled for reference purposes only; where discrepancies are found they are subject to change without notice. Bolt & Nut Australia makes no warranties or representations regarding the accuracy and validity of the compiled information and data. Contact the relevant standard authorities for accurate and detailed information.

© Bolt & Nut Australia Pty Ltd. All rights reserved.

Version: 17 Mar 2026