

*Disclaimer: Images are for illustrative purposes.*

## Standard Full Nut

**Thread Type:** Metric - Coarse

**Thread Direction:** Right Hand

**Material:** Carbon Steel

**Class Grade:** High Tensile Class 8

**Finish:** Can be either Plain Black uncoated or a Bright Steel appearance

**Corrosion Protection Level:** Very Low

**Standard:** AS 1112

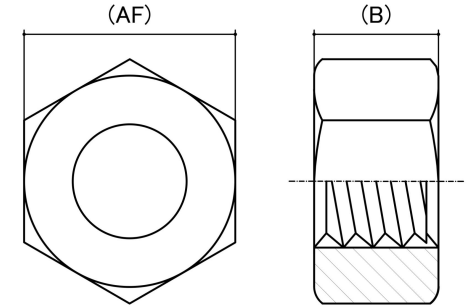

Size	Thread Pitch (mm)	Thread Type	Overall Nut Height (B) (mm)		Across Flats (AF) (mm)		Spanner Size (AF) (mm)	sku (Part Number)
			Min	Max	Min	Max		
M6	1.00mm	Coarse	4.90	5.20	9.78	10.00	10mm	416P
M8	1.25mm	Coarse	6.44	6.93	12.73	13.00	13mm	418P
M10	1.50mm	Coarse	8.04	8.40	15.73	16.00	16mm	4110P
M12	1.75mm	Coarse	10.37	10.80	17.73	18.00	18mm	4112P
M14	2.00mm	Coarse	12.10	12.80	20.67	21.00	21mm	4114P
M16	2.00mm	Coarse	14.10	14.80	23.67	24.00	24mm	4116P
M18	2.50mm	Coarse	14.30	15.00	23.67	24.00	24mm	4118P
M20	2.50mm	Coarse	16.90	18.00	29.16	30.00	30mm	4120P
M22	2.50mm	Coarse	19.80	21.10	33.00	34.00	34mm	4122P
M24	3.00mm	Coarse	20.20	21.50	35.16	36.00	36mm	4124P
M30	3.50mm	Coarse	24.30	25.60	45.00	46.00	46mm	4130P

**Disclaimer:**

Dimensional data and technical information was obtained from publicly available sources and not acquired through standard agencies. It has been completed and compiled for reference purposes only; where discrepancies are found they are subject to change without notice. Bolt & Nut Australia makes no warranties or representations regarding the accuracy and validity of the compiled information and data. Contact the relevant standard authorities for accurate and detailed information.

© Bolt & Nut Australia Pty Ltd. All rights reserved.

Version: 17 Mar 2026