

Disclaimer: Images are for illustrative purposes.

Standard Full Nut

Thread Type: Metric - Coarse

Thread Direction: Right Hand

Material: Carbon Steel

Class Grade: High Tensile Class 8

Finish: Zinc Plated

Corrosion Protection Level: Moderate

Standard: AS 1112

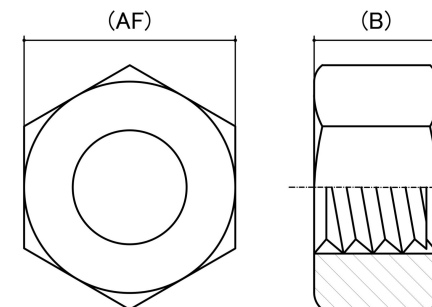

| Size | Thread Pitch (mm) | Thread Type | Overall Nut Height (B) (mm) | | Across Flats (AF) (mm) | | Spanner Size (AF) (mm) | sku (Part Number) |
|------|-------------------|-------------|-----------------------------|-------|------------------------|-------|------------------------|-------------------|
| | | | Min | Max | Min | Max | | |
| M3 | 0.50mm | Coarse | 2.15 | 2.40 | 5.32 | 5.50 | 5.5mm | 413 |
| M4 | 0.70mm | Coarse | 2.90 | 3.30 | 6.78 | 7.00 | 7mm | 414 |
| M5 | 0.80mm | Coarse | 4.40 | 4.70 | 7.78 | 8.00 | 8mm | 415 |
| M6 | 1.00mm | Coarse | 4.90 | 5.20 | 9.78 | 10.00 | 10mm | 416 |
| M8 | 1.25mm | Coarse | 6.44 | 6.93 | 12.73 | 13.00 | 13mm | 418 |
| M10 | 1.50mm | Coarse | 8.04 | 8.40 | 15.73 | 16.00 | 16mm | 4110 |
| M12 | 1.75mm | Coarse | 10.37 | 10.80 | 17.73 | 18.00 | 18mm | 4112 |
| M14 | 2.00mm | Coarse | 12.10 | 12.80 | 20.67 | 21.00 | 21mm | 4114 |
| M16 | 2.00mm | Coarse | 14.10 | 14.80 | 23.67 | 24.00 | 24mm | 4116 |
| M18 | 2.50mm | Coarse | 15.10 | 15.80 | 26.16 | 27.00 | 27mm | 4118 |
| M20 | 2.50mm | Coarse | 16.90 | 18.00 | 29.16 | 30.00 | 30mm | 4120 |
| M22 | 2.50mm | Coarse | 19.80 | 21.10 | 33.00 | 34.00 | 34mm | 4122 |
| M24 | 3.00mm | Coarse | 20.20 | 21.50 | 35.16 | 36.00 | 36mm | 4124 |
| M30 | 3.50mm | Coarse | 24.30 | 25.60 | 45.00 | 46.00 | 46mm | 4130 |
| M36 | 4.00mm | Coarse | 29.40 | 31.00 | 53.80 | 55.00 | 55mm | 4136 |

| Size | Thread Pitch (mm) | Thread Type | Overall Nut Height (B) (mm) | | Across Flats (AF) (mm) | | Spanner Size (AF) (mm) | sku (Part Number) |
|------|-------------------|-------------|-----------------------------|-------|------------------------|-------|------------------------|-------------------|
| | | | Min | Max | Min | Max | | |
| M42 | 4.50mm | Coarse | 32.40 | 34.90 | 63.10 | 65.00 | 65mm | 4142 |

Disclaimer:

Dimensional data and technical information was obtained from publically available sources and not acquired through standard agencies. It has been completed and compiled for reference purposes only; where discrepancies are found they are subject to change without notice. Bolt & Nut Australia makes no warranties or representations regarding the accuracy and validity of the compiled information and data. Contact the relevant standard authorities for accurate and detailed information.

© Bolt & Nut Australia Pty Ltd. All rights reserved.

Version: 17 Mar 2026