

Disclaimer: Images are for illustrative purposes.

Standard Full Nut

Thread Type: UNC / BSW - Coarse

Thread Direction: Right Hand

Material: Carbon Steel

Class Grade: High Tensile Class 8

Finish: Can be either Plain Black uncoated or a Bright Steel appearance

Corrosion Protection Level: Very Low

Standard: AS 2465

Comments: UNC and BSW have the same thread per inch (TPI) value, except for 1/2"

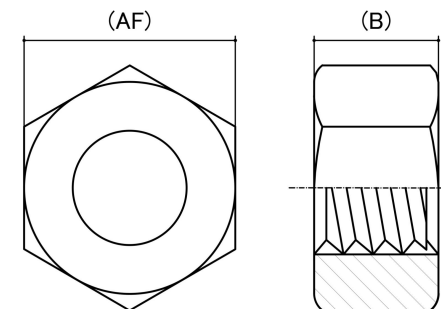

Size	Thread Pitch (TPI)	Thread Type	Overall Nut Height (B) (mm)		Across Flats (AF) (mm)		Spanner Size (AF) (inches)	sku (Part Number)
			Min	Max	Min	Max		
1/4"	20 TPI	Coarse	5.39	5.75	10.88	11.16	7/16"	41C14P
5/16"	18 TPI	Coarse	6.56	6.94	12.43	12.76	1/2"	41C516P
3/8"	16 TPI	Coarse	8.13	8.56	14.00	14.28	9/16"	41C38P
7/16"	14 TPI	Coarse	9.28	9.78	17.15	17.48	11/16"	41C716P
1/2"	13 TPI	Coarse	10.85	11.38	18.70	19.05	3/4"	41C12P
9/16"	12 TPI	Coarse	12.02	12.60	21.87	22.23	7/8"	41C916P
5/8"	11 TPI	Coarse	13.59	14.20	23.42	23.83	15/16"	41C58P
3/4"	10 TPI	Coarse	15.68	16.90	27.64	28.58	1-1/8"	41C34P
7/8"	9 TPI	Coarse	18.39	19.72	32.24	33.33	1-5/16"	41C78P
1"	8 TPI	Coarse	21.11	22.53	36.83	38.16	1-1/2"	41C1P

Disclaimer:

Dimensional data and technical information was obtained from publicly available sources and not acquired through standard agencies. It has been completed and compiled for reference purposes only; where discrepancies are found they are subject to change without notice. Bolt & Nut Australia makes no warranties or representations regarding the accuracy and validity of the compiled information and data. Contact the relevant standard authorities for accurate and detailed information.

© Bolt & Nut Australia Pty Ltd. All rights reserved.

Version: 17 Mar 2026