

*Disclaimer: Images are for illustrative purposes.*

## Standard Full Nut

**Thread Type:** UNC / BSW - Coarse

**Thread Direction:** Right Hand

**Material:** Carbon Steel

**Class Grade:** High Tensile Grade 8

**Finish:** Zinc Plated

**Corrosion Protection Level:** Moderate

**Standard:** AS 2465

**Comments:** UNC and BSW have the same thread per inch (TPI) value, except for 1/2"

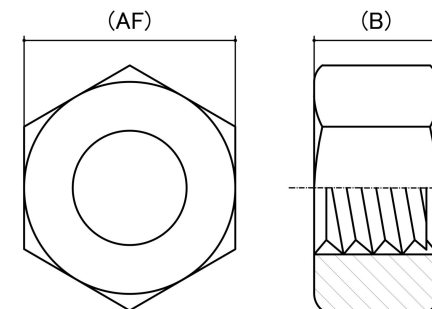

Size	Thread Pitch (TPI)	Thread Type	Overall Nut Height (B) (mm)		Across Flats (AF) (mm)		Spanner Size (AF) (inches)	sku (Part Number)
			Min	Max	Min	Max		
1/4"	20 TPI	Coarse	5.39	5.75	10.88	11.16	7/16"	41C14
5/16"	18 TPI	Coarse	6.56	6.94	12.43	12.76	1/2"	41C516
3/8"	16 TPI	Coarse	8.13	8.56	14.00	14.28	9/16"	41C38
7/16"	14 TPI	Coarse	9.28	9.78	17.15	17.48	11/16"	41C716
1/2"	13 TPI	Coarse	10.85	11.38	18.70	19.05	3/4"	41C12
9/16"	12 TPI	Coarse	12.02	12.60	21.87	22.23	7/8"	41C916
5/8"	11 TPI	Coarse	13.59	14.20	23.42	23.83	15/16"	41C58
3/4"	10 TPI	Coarse	15.68	16.90	27.64	28.58	1-1/8"	41C34
7/8"	9 TPI	Coarse	18.39	19.72	32.24	33.33	1-5/16"	41C78
1"	8 TPI	Coarse	21.11	22.53	36.83	38.16	1-1/2"	41C1
1-1/8"	7 TPI	Coarse	23.90	25.40	41.40	42.90	1-11/16"	41C118
1-1/4"	7 TPI	Coarse	26.20	27.80	46.00	47.60	1-7/8"	41C114
1-3/8"	6 TPI	Coarse	28.90	30.60	50.60	52.40	2-1/16"	41C138
1-1/2"	6 TPI	Coarse	31.60	34.80	55.20	57.20	2-1/4"	41C112
1-3/4"	5 TPI	Coarse	37.30	38.90	65.20	66.70	2-5/8"	41C134

**Disclaimer:**

Dimensional data and technical information was obtained from publically available sources and not acquired through standard agencies. It has been completed and compiled for reference purposes only; where discrepancies are found they are subject to change without notice. Bolt & Nut Australia makes no warranties or representations regarding the accuracy and validity of the compiled information and data. Contact the relevant standard authorities for accurate and detailed information.