

Disclaimer: Images are for illustrative purposes.

Standard Full Nut

Thread Type: UNF - Fine

Thread Direction: Right Hand

Material: Carbon Steel

Class Grade: High Tensile Grade 8

Finish: Zinc Plated

Corrosion Protection Level: Moderate

Standard: AS 2465

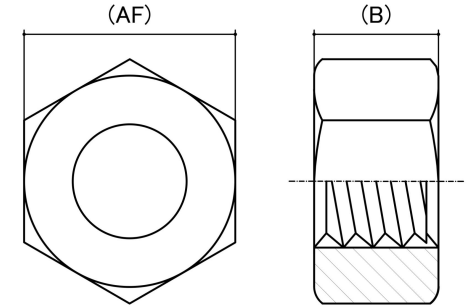

Size	Thread Pitch (TPI)	Thread Type	Overall Nut Height (B) (mm)		Across Flats (AF) (mm)		Spanner Size (AF) (inches)	sku (Part Number)
			Min	Max	Min	Max		
1/4"	28 TPI	Fine	5.39	5.75	10.88	11.16	7/16"	41F14
5/16"	24 TPI	Fine	6.56	6.94	12.43	12.76	1/2"	41F516
3/8"	24 TPI	Fine	8.13	8.56	14.00	14.28	9/16"	41F38
7/16"	20 TPI	Fine	9.28	9.78	17.15	17.48	11/16"	41F716
1/2"	20 TPI	Fine	10.85	11.38	18.70	19.05	3/4"	41F12
9/16"	18 TPI	Fine	12.02	12.60	21.87	22.23	7/8"	41F916
5/8"	18 TPI	Fine	13.59	14.20	23.42	23.83	15/16"	41F58
3/4"	16 TPI	Fine	15.68	16.90	27.64	28.58	1-1/8"	41F34
7/8"	14 TPI	Fine	18.39	19.72	32.24	33.33	1-5/16"	41F78
1"	12 TPI	Fine	21.11	22.53	36.83	38.16	1-1/2"	41F1
1"	14 TPI	Fine	21.11	22.53	36.83	38.16	1-1/2"	41F1F
1-1/8"	12 TPI	Fine	23.90	25.40	41.40	42.90	1-11/16"	41F118
1-1/4"	12 TPI	Fine	26.20	27.80	46.00	47.60	1-7/8"	41F114
1-3/8"	12 TPI	Fine	28.90	30.60	50.60	52.40	2-1/16"	41F138
1-1/2"	12 TPI	Fine	31.60	34.80	55.20	57.20	2-1/4"	41F112

Size	Thread Pitch (TPI)	Thread Type	Overall Nut Height (B) (mm)		Across Flats (AF) (mm)		Spanner Size (AF) (inches)	sku (Part Number)
			Min	Max	Min	Max		
1-3/4"	12 TPI	Fine	37.30	38.90	65.20	66.70	2-5/8"	41F134
2"	12 TPI	Fine	42.80	44.60	74.70	76.20	3"	41F2

Disclaimer:

Dimensional data and technical information was obtained from publically available sources and not acquired through standard agencies. It has been completed and compiled for reference purposes only; where discrepancies are found they are subject to change without notice. Bolt & Nut Australia makes no warranties or representations regarding the accuracy and validity of the compiled information and data. Contact the relevant standard authorities for accurate and detailed information.

© Bolt & Nut Australia Pty Ltd. All rights reserved.

Version: 17 Mar 2026