

*Disclaimer: Images are for illustrative purposes.*

## K-Lock Nut & External Lockwasher

**Thread Type:** Metric - Coarse

**Thread Direction:** Right Hand

**Material:** Carbon Steel

**Class Grade:** Low Tensile Class 5

**Finish:** Zinc Plated

**Corrosion Protection Level:** Moderate

**Standard:** DIN 934K

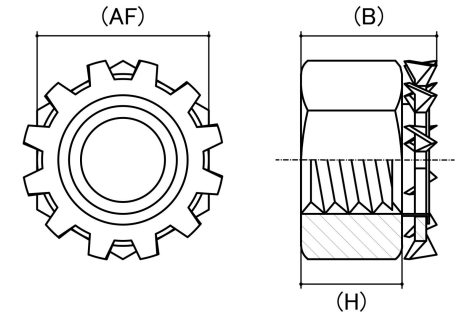

Size	Thread Pitch (mm)	Thread Type	Overall Nut Height (B) (mm)		Across Flats (AF) (mm)		Spanner Size (AF) (mm)	sku (Part Number)
			Min	Max	Min	Max		
M5	0.80mm	Coarse	4.80	5.10	7.78	8.00	8mm	41KL5
M6	1.00mm	Coarse	4.90	5.20	9.78	10.00	10mm	41KL6

**Disclaimer:**

Dimensional data and technical information was obtained from publically available sources and not acquired through standard agencies. It has been completed and compiled for reference purposes only; where discrepancies are found they are subject to change without notice. Bolt & Nut Australia makes no warranties or representations regarding the accuracy and validity of the compiled information and data. Contact the relevant standard authorities for accurate and detailed information.

© Bolt & Nut Australia Pty Ltd. All rights reserved.

Version: 17 Mar 2026