

Disclaimer: Images are for illustrative purposes.

Nyloc Insert Nut

Thread Type: Metric - Coarse

Thread Direction: Right Hand

Material: High Tensile Stainless Steel

Class Grade: High Tensile A4-80 G316

Corrosion Protection Level: Ultimate

Standard: DIN 985

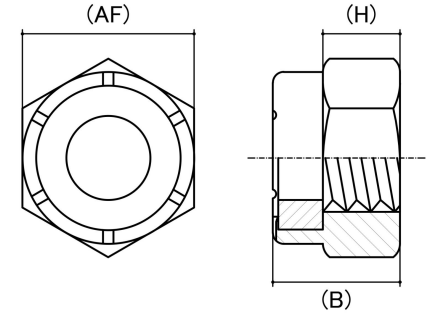

Size	Thread Pitch (mm)	Thread Type	Overall Nut Height (B) (mm)		Hex Height (H) (mm)	Across Flats (AF) (mm)		Spanner Size (AF) (mm)	sku (Part Number)
			Min	Max	Nom	Min	Max		
M4	0.70mm	Coarse	4.70	5.00	3.20	6.78	7.00	7mm	41NS4MN
M5	0.80mm	Coarse	4.70	5.00	3.20	7.78	8.00	8mm	41NS5MN
M6	1.00mm	Coarse	5.70	6.00	4.00	9.78	10.00	10mm	41NS6MN
M8	1.25mm	Coarse	7.64	8.00	5.50	12.73	13.00	13mm	41NS8MN
M10	1.50mm	Coarse	9.64	10.00	6.50	16.73	17.00	17mm	41NS10MN
M12	1.75mm	Coarse	11.57	12.00	8.00	18.67	19.00	19mm	41NSM12MN
M16	2.00mm	Coarse	15.30	16.00	10.50	23.67	24.00	24mm	41NS16MN
M20	2.50mm	Coarse	18.67	20.00	14.00	29.16	30.00	30mm	41NS20MN
M24	3.00mm	Coarse	23.15	24.00	15.00	35.16	36.00	36mm	41NS24MN
M30	3.50mm	Coarse	28.70	30.00	19.00	45.00	46.00	46mm	41NS30MN

Disclaimer:

Dimensional data and technical information was obtained from publicly available sources and not acquired through standard agencies. It has been completed and compiled for reference purposes only; where discrepancies are found they are subject to change without notice. Bolt & Nut Australia makes no warranties or representations regarding the accuracy and validity of the compiled information and data. Contact the relevant standard authorities for accurate and detailed information.

© Bolt & Nut Australia Pty Ltd. All rights reserved.

Version: 17 Mar 2026