

## Square Section Spring Washer

**Material:** High Tensile Class 8.8 Stainless Steel

**Class Grade:** A4-80 High Tensile G316

**Corrosion Protection Level:** Ultimate

**Standard:** DIN 7980

**System Of Measurement:** Metric

**Comments:** Washers are not precision items. Dimensional data should be used as a guide only.

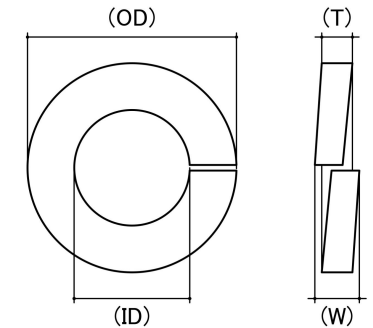

*Cad Drawings shown for graphic representation only.\**

Industry Size (mm)	Inside Dimension (ID) (mm)		Outside Dimension (OD) (mm)	Thickness (T) (mm)	Height (W) (mm)	Stamped	sku (Part Number)
	Min	Max		Nom	Nom		
M4 (4mm)	4.10	4.50	7.00	1.30	2.60	No	71PS4MN
M5 (5mm)	5.10	5.50	8.80	1.70	3.50	No	71PS5MN
M6 (6mm)	6.10	6.70	9.90	1.70	3.50	No	71PS6MN
M8 (8mm)	8.00	8.50	12.70	2.10	4.40	No	71PS8MN
M10 (10mm)	10.20	10.75	16.00	2.60	5.50	No	71PS10MN
M12 (12mm)	12.20	13.00	18.00	2.60	5.50	No	71PSM12MN
M14 (14mm)	14.20	14.70	21.10	3.20	6.50	No	71PS14MN
M16 (16mm)	16.20	17.00	24.40	3.70	7.60	No	71PS16MN
M20 (20mm)	20.90	22.10	30.60	4.70	9.80	No	71PS20MN

**Disclaimer:**

Dimensional data and technical information was obtained from publically available sources and not acquired through standard agencies. It has been completed and compiled for reference purposes only; where discrepancies are found they are subject to change without notice. Bolt & Nut Australia makes no warranties or representations regarding the accuracy and validity of the compiled information and data. Contact the relevant standard authorities for accurate and detailed information.

\* Cad Drawings may not reflect diameter, thread length or overall length.

© Bolt & Nut Australia Pty Ltd. All rights reserved.

Version: 04 Sep 2024