

Disclaimer: Images are for illustrative purposes.

Thin Large Flange Head Nutsert

Body Type: Round Open

Outside Body: Splined | Knurled

Thread Type: UNC / BSW - Coarse

Body Material: Low Carbon Steel

Finish: Zinc Plated

Corrosion Protection Level: Moderate

Comments: Before installing check that your Tool capabilities cover required size and material. We recommend using a paste on the mandrel thread to prolong mandrel life

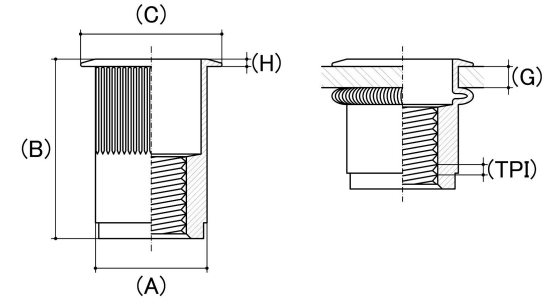

Size	Thread Pitch (TPI)	Thread Type	Material Grip Range (G) (mm)		Overall Nut Height (B) (mm)	Head Diameter (C) (mm)	Nut Width (A) (mm)	Flange Thickness (H) (mm)	Recommended Hole Size (mm)	Pull Out (KN)	Push Out (KN)	Torque To Turn (NM)	sku (Part Number)
			Min	Max	Nom	Nom	Nom	Nom					
3/16" (#10-24)	24 TPI	Coarse	0.50	3.30	12.90	10.50	7.50	0.76	7.60	4	2	8	43ALC1024SP
1/4"	20 TPI	Coarse	0.70	4.20	15.50	12.70	9.91	0.76	10.00	9	2	16	43ALC14SP
5/16"	18 TPI	Coarse	0.70	3.80	18.40	17.40	13.40	0.89	13.50	19	3	26	43ALC516SP
3/8"	16 TPI	Coarse	0.70	3.80	18.40	17.40	13.40	0.89	13.50	19	3	32	43ALC38SP

Disclaimer:

Dimensional data and technical information was obtained from publically available sources and not acquired through standard agencies. It has been completed and compiled for reference purposes only; where discrepancies are found they are subject to change without notice. Bolt & Nut Australia makes no warranties or representations regarding the accuracy and validity of the compiled information and data. Contact the relevant standard authorities for accurate and detailed information.

© Bolt & Nut Australia Pty Ltd. All rights reserved.

Version: 17 Mar 2026