

Disclaimer: Images are for illustrative purposes.

Nyloc Insert Nut

Thread Type: BSW - Coarse

Thread Direction: Right Hand

Material: Carbon Steel

Class Grade: Low Tensile Grade 2

Finish: Mechanically Galvanised

Corrosion Protection Level: Excellent

Standard: IFI-100NE

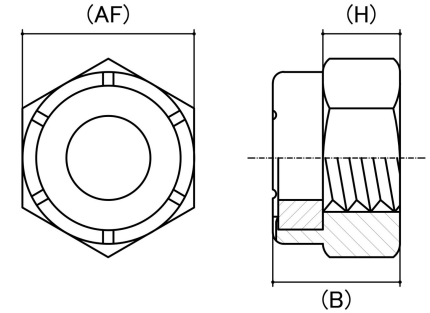

Size	Thread Pitch (TPI)	Thread Type	Overall Nut Height (B) (mm)		Hex Height (H) (mm)	Across Flats (AF) (mm)		Spanner Size (AF) (inches)	sku (Part Number)
			Min	Max	Nom	Min	Max		
1/2"	12 TPI	Coarse	14.70	15.45	11.79	18.70	19.05	3/4"	41NW12MG

Disclaimer:

Dimensional data and technical information was obtained from publically available sources and not acquired through standard agencies. It has been completed and compiled for reference purposes only; where discrepancies are found they are subject to change without notice. Bolt & Nut Australia makes no warranties or representations regarding the accuracy and validity of the compiled information and data. Contact the relevant standard authorities for accurate and detailed information.

© Bolt & Nut Australia Pty Ltd. All rights reserved.

Version: 17 Mar 2026