

Disclaimer: Images are for illustrative purposes.

Nyloc Insert Nut

Thread Type: Metric - Coarse

Thread Direction: Right Hand

Material: Carbon Steel

Class Grade: High Tensile Class 8

Finish: Zinc Plated

Corrosion Protection Level: Moderate

Standard: DIN 985

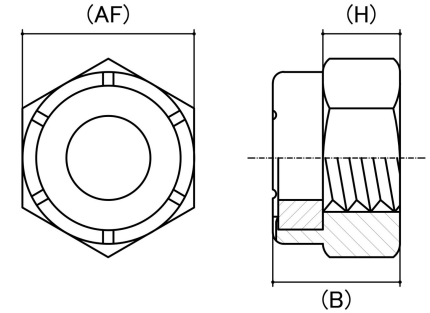

Size	Thread Pitch (mm)	Thread Type	Overall Nut Height (B) (mm)		Hex Height (H) (mm)	Across Flats (AF) (mm)		Spanner Size (AF) (mm)	sku (Part Number)
			Min	Max	Nom	Min	Max		
M2.5	0.45mm	Coarse	3.30	3.60	2.00	4.82	5.00	5mm	41N25
M3	0.50mm	Coarse	3.70	4.00	2.40	5.32	5.50	5.5mm	41N3
M4	0.70mm	Coarse	4.70	5.00	3.20	6.78	7.00	7mm	41N4
M5	0.80mm	Coarse	4.70	5.00	3.20	7.78	8.00	8mm	41N5
M6	1.00mm	Coarse	5.70	6.00	4.00	9.78	10.00	10mm	41N6
M8	1.25mm	Coarse	7.64	8.00	5.50	12.73	13.00	13mm	41N8
M10	1.50mm	Coarse	9.64	10.00	6.50	16.73	17.00	17mm	41N10
M12	1.75mm	Coarse	11.57	12.00	8.00	18.67	19.00	19mm	41N12
M14	2.00mm	Coarse	13.30	14.00	9.50	21.67	22.00	22mm	41N14
M16	2.00mm	Coarse	15.30	16.00	10.50	23.67	24.00	24mm	41N16
M18	2.50mm	Coarse	17.66	18.50	13.00	26.16	27.00	27mm	41N18
M20	2.50mm	Coarse	18.67	20.00	14.00	29.16	30.00	30mm	41N20
M22	2.50mm	Coarse	20.70	22.00	15.00	31.00	32.00	32mm	41N22
M24	3.00mm	Coarse	23.15	24.00	15.00	35.16	36.00	36mm	41N24
M27	3.00mm	Coarse	25.70	27.00	17.00	40.00	41.00	41mm	41N27

Size	Thread Pitch (mm)	Thread Type	Overall Nut Height (B) (mm)		Hex Height (H) (mm)	Across Flats (AF) (mm)		Spanner Size (AF) (mm)	sku (Part Number)
			Min	Max	Nom	Min	Max		
M30	3.50mm	Coarse	28.70	30.00	19.00	45.00	46.00	46mm	41N30
M33	3.50mm	Coarse	31.40	33.00	22.00	49.00	50.00	50mm	41N33
M36	4.00mm	Coarse	34.40	36.00	25.00	53.80	55.00	55mm	41N36

Disclaimer:

Dimensional data and technical information was obtained from publically available sources and not acquired through standard agencies. It has been completed and compiled for reference purposes only; where discrepancies are found they are subject to change without notice. Bolt & Nut Australia makes no warranties or representations regarding the accuracy and validity of the compiled information and data. Contact the relevant standard authorities for accurate and detailed information.

© Bolt & Nut Australia Pty Ltd. All rights reserved.

Version: 17 Mar 2026