

Disclaimer: Images are for illustrative purposes.

Plow Nut

Thread Type: UNC / BSW - Coarse

Thread Direction: Right Hand

Material: Carbon Steel

Class Grade: High Tensile Grade 8

Finish: Can be either Plain Black uncoated or a Bright Steel appearance

Corrosion Protection Level: Very Low

Standard: HEC / GR8

Comments: UNC and BSW have the same thread per inch (TPI) value, except for 1/2"

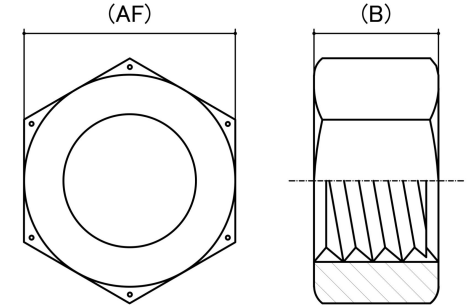

Size	Thread Pitch (TPI)	Thread Type	Overall Nut Height (B) (mm)		Across Flats (AF) (mm)		Spanner Size (AF) (inches)	sku (Part Number)
			Min	Max	Min	Max		
5/8"	11 TPI	Coarse	13.59	14.20	23.42	23.83	15/16"	41PC58P
3/4"	10 TPI	Coarse	15.68	16.90	27.64	28.58	1-1/8"	41PC34P
7/8"	9 TPI	Coarse	18.39	19.72	32.24	33.33	1-5/16"	41PC78P
1"	8 TPI	Coarse	21.11	22.53	36.83	38.16	1-1/2"	41PC1P
1-1/4"	7 TPI	Coarse	26.20	27.80	46.00	47.60	1-7/8"	41PC114P
1-3/8"	6 TPI	Coarse	28.90	30.60	50.64	52.38	2-1/16"	41PC138P

Disclaimer:

Dimensional data and technical information was obtained from publicly available sources and not acquired through standard agencies. It has been completed and compiled for reference purposes only; where discrepancies are found they are subject to change without notice. Bolt & Nut Australia makes no warranties or representations regarding the accuracy and validity of the compiled information and data. Contact the relevant standard authorities for accurate and detailed information.

© Bolt & Nut Australia Pty Ltd. All rights reserved.

Version: 17 Mar 2026