

Flat Section Spring Washer

Material: Mild Steel

Class Grade: Low Tensile Class 4.6

Corrosion Protection Level: Excellent

Finish: Galvanised

Standard: DIN 127B

System Of Measurement: Metric

Comments: Washers are not precision items. Dimensional data should be used as a guide only.

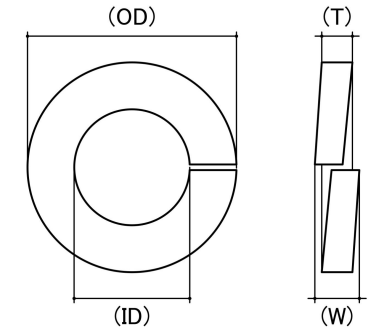

*Cad Drawings shown for graphic representation only.**

Industry Size (mm)	Inside Dimension (ID) (mm)		Outside Dimension (OD) (mm)		Thickness (T) (mm)		Height (W) (mm)	sku (Part Number)
	Min	Max	Min	Max	Min	Max	Nom	
M6 (6mm)	6.10	6.70	11.20	12.00	1.50	1.70	2.90	71P6G
M8 (8mm)	8.00	8.50	14.20	15.00	1.90	2.10	3.70	71P8G
M10 (10mm)	10.20	10.75	17.30	18.00	2.10	2.30	4.45	71P10G
M12 (12mm)	12.20	13.00	20.20	21.00	2.40	2.60	4.40	71PM12G
M16 (16mm)	16.20	17.00	26.30	27.00	3.40	3.60	6.65	71P16G
M20 (20mm)	20.90	22.10	32.50	33.50	3.90	4.10	7.90	71P20G
M24 (24mm)	24.50	26.50	38.50	40.00	4.90	5.10	9.50	71P24G
M30 (30mm)	32.00	33.00	47.00	48.00	5.90	6.10	11.60	71P30G

Disclaimer:

Dimensional data and technical information was obtained from publically available sources and not acquired through standard agencies. It has been completed and compiled for reference purposes only; where discrepancies are found they are subject to change without notice. Bolt & Nut Australia makes no warranties or representations regarding the accuracy and validity of the compiled information and data. Contact the relevant standard authorities for accurate and detailed information.

* Cad Drawings may not reflect diameter, thread length or overall length.

© Bolt & Nut Australia Pty Ltd. All rights reserved.

Version: 15 Aug 2024