

Disclaimer: Images are for illustrative purposes.

Chamfered Square Nut

Thread Type: Metric - Coarse

Thread Direction: Right Hand

Material: Carbon Steel

Class Grade: Low Tensile Class 5

Finish: Galvanised

Corrosion Protection Level: Excellent

Standard: DIN 557

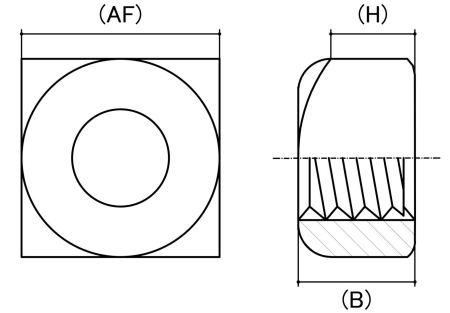

Size	Thread Pitch (mm)	Thread Type	Overall Nut Height (B) (mm)		Hex Height (H) (mm)	Across Flats (AF) (mm)		Spanner Size (AF) (mm)	sku (Part Number)
			Min	Max	Nom	Min	Max		
M6	1.00mm	Coarse	4.52	5.00	3.20	9.64	10.00	10mm	41SQ6G
M8	1.25mm	Coarse	5.92	6.50	4.10	12.57	13.00	13mm	41SQ8G
M10	1.50mm	Coarse	7.42	8.00	5.20	16.57	17.00	17mm	41SQ10G
M12	1.75mm	Coarse	9.42	10.00	6.60	18.48	19.00	19mm	41SQ12G
M16	2.00mm	Coarse	12.30	13.00	8.60	23.16	24.00	24mm	41SQ16G
M20	2.50mm	Coarse	15.30	16.00	-	29.16	30.00	30mm	41SQ20G
M24	3.00mm	Coarse	18.30	19.00	-	35.16	36.00	36mm	41SQ24G

Disclaimer:

Dimensional data and technical information was obtained from publicly available sources and not acquired through standard agencies. It has been completed and compiled for reference purposes only; where discrepancies are found they are subject to change without notice. Bolt & Nut Australia makes no warranties or representations regarding the accuracy and validity of the compiled information and data. Contact the relevant standard authorities for accurate and detailed information.

© Bolt & Nut Australia Pty Ltd. All rights reserved.

Version: 17 Mar 2026