

Disclaimer: Images are for illustrative purposes.

Structural Nut

Thread Type: Metric - Coarse

Thread Direction: Right Hand

Material: Carbon Steel

Class Grade: High Tensile Class 8

Finish: Galvanised

Corrosion Protection Level: Excellent

Standard: K0 AS 1252:2016

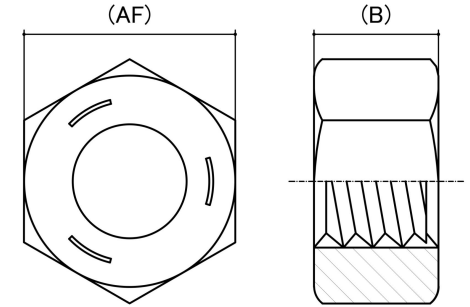

Size	Thread Pitch (mm)	Thread Type	Overall Nut Height (B) (mm)		Across Flats (AF) (mm)		Spanner Size (AF) (mm)	sku (Part Number)
			Min	Max	Min	Max		
M12	1.75mm	Coarse	12.00	13.10	20.16	21.00	21mm	41G12GK0
M16	2.00mm	Coarse	16.00	17.10	26.16	27.00	27mm	41G16GK0
M20	2.50mm	Coarse	20.00	21.30	31.00	32.00	32mm	41G20GK0
M22	2.50mm	Coarse	22.00	23.30	35.00	36.00	36mm	41G22GK0
M24	3.00mm	Coarse	24.00	25.30	40.00	41.00	41mm	41G24GK0
M27	3.00mm	Coarse	27.00	28.30	45.00	46.00	46mm	41G27GK0
M30	3.50mm	Coarse	30.00	31.30	49.00	50.00	50mm	41G30GK0
M33	3.50mm	Coarse	32.00	33.00	53.00	54.00	54mm	41G33GK0
M36	4.00mm	Coarse	36.00	37.60	58.80	60.00	60mm	41G36GK0

Disclaimer:

Dimensional data and technical information was obtained from publically available sources and not acquired through standard agencies. It has been completed and compiled for reference purposes only; where discrepancies are found they are subject to change without notice. Bolt & Nut Australia makes no warranties or representations regarding the accuracy and validity of the compiled information and data. Contact the relevant standard authorities for accurate and detailed information.

© Bolt & Nut Australia Pty Ltd. All rights reserved.

Version: 17 Mar 2026