

Disclaimer: Images are for illustrative purposes.

Thin Nyloc Nut

Thread Type: Metric - Coarse

Thread Direction: Right Hand

Material: Carbon Steel

Class Grade: Low Tensile Class 4

Finish: Zinc Plated

Corrosion Protection Level: Moderate

Standard: ISO 10511

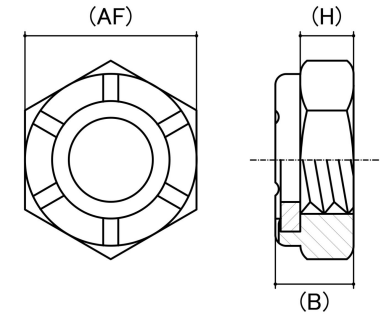

Size	Thread Pitch (mm)	Thread Type	Overall Nut Height (B) (mm)		Hex Height (H) (mm)	Across Flats (AF) (mm)		Spanner Size (AF) (mm)	sku (Part Number)
			Min	Max	Nom	Min	Max		
M10	1.50mm	Coarse	7.98	8.56	4.70	16.73	17.00	17mm	41NL10
M12	1.75mm	Coarse	9.53	10.23	5.70	18.67	19.00	19mm	41NL12
M16	2.00mm	Coarse	11.32	12.42	7.42	23.67	24.00	24mm	41NL16
M20	2.50mm	Coarse	14.10	14.70	9.10	29.16	30.00	30mm	41NL20
M24	3.00mm	Coarse	16.90	17.50	10.90	35.16	36.00	36mm	41NL24
M30	3.50mm	Coarse	21.10	22.20	13.90	45.00	46.00	46mm	41NL30
M36	4.00mm	Coarse	24.50	25.40	16.90	53.80	55.00	55mm	41NL36

Disclaimer:

Dimensional data and technical information was obtained from publicly available sources and not acquired through standard agencies. It has been completed and compiled for reference purposes only; where discrepancies are found they are subject to change without notice. Bolt & Nut Australia makes no warranties or representations regarding the accuracy and validity of the compiled information and data. Contact the relevant standard authorities for accurate and detailed information.

© Bolt & Nut Australia Pty Ltd. All rights reserved.

Version: 17 Mar 2026