

Disclaimer: Images are for illustrative purposes.

Weld Nut

Thread Type: Metric - Coarse

Thread Direction: Right Hand

Material: Stainless Steel

Class Grade: A2-70 G304

Corrosion Protection Level: Excellent

Standard: DIN 929

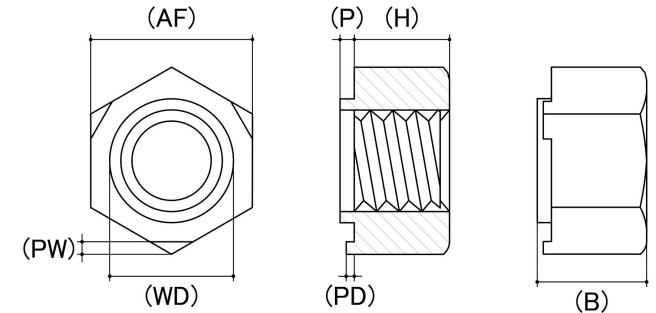

Size	Thread Pitch (mm)	Thread Type	Overall Nut Height (B) (mm)		Projection Width (PW) (mm)		Projection Height (PD) (mm)		Pilot Height (P) (mm)		Diameter of the Weld (WD) (mm)		Sheet Metal Thickness (mm)		Across Flats (AF) (mm)		Spanner Size (AF) (mm)	sku (Part Number)
			Min	Max	Min	Max	Min	Max	Min	Max	Min	Max	Min	Max	Min	Max		
M3	0.50mm	Coarse	2.75	3.00	0.60	1.00	0.15	0.25	0.45	0.55	4.39	4.50	0.63	2.50	7.28	7.50	7.5mm	41WES3
M4	0.70mm	Coarse	3.20	3.50	0.60	1.00	0.20	0.30	0.50	0.65	5.90	6.00	0.75	3.00	8.78	9.00	9mm	41WES4
M5	0.80mm	Coarse	3.70	4.00	0.60	1.00	0.30	0.45	0.65	0.75	6.90	7.10	0.88	3.50	9.78	10.00	10mm	41WES5
M6	1.00mm	Coarse	4.70	5.00	0.80	1.10	0.40	0.50	0.65	0.80	7.90	8.10	0.88	4.00	10.73	11.00	11mm	41WES6
M8	1.25mm	Coarse	6.14	6.50	1.00	1.20	0.50	0.60	0.70	0.90	10.40	10.60	1.00	4.50	13.73	14.00	14mm	41WES8
M10	1.50mm	Coarse	7.64	8.00	1.00	1.30	0.60	0.70	1.00	1.20	12.40	12.60	1.25	5.00	16.73	17.00	17mm	41WES10
M12	1.75mm	Coarse	9.64	10.00	1.20	1.50	0.65	0.80	1.10	1.30	14.60	14.80	1.50	5.00	18.67	19.00	19mm	41WES12

Disclaimer:

Dimensional data and technical information was obtained from publically available sources and not acquired through standard agencies. It has been completed and compiled for reference purposes only; where discrepancies are found they are subject to change without notice. Bolt & Nut Australia makes no warranties or representations regarding the accuracy and validity of the compiled information and data. Contact the relevant standard authorities for accurate and detailed information.

© Bolt & Nut Australia Pty Ltd. All rights reserved.

Version: 17 Mar 2026